



... this is **not** how we teach **swimming** in Faroese schools!

Helgi Winther Olsen

**Exercise Science and Physical Education
PhD candidate**

**Faculty of Teaching
University of the Faroe Islands**



Hey

Helgi

Bára





Iceland

o Reykjavik

Faroe Islands
54.679

Norway



A nerd with interest for spineless snails

DAGUR & VIKA

HELGI WINTHER OLSEN

nørdur við áhuga fyrir ryggleysum sniglum



Fascination
Curiosity
Drive





So, what is
swimming in
Faroese schools?

... this is **not** how
we teach **swimming**
in the Faroese
schools!

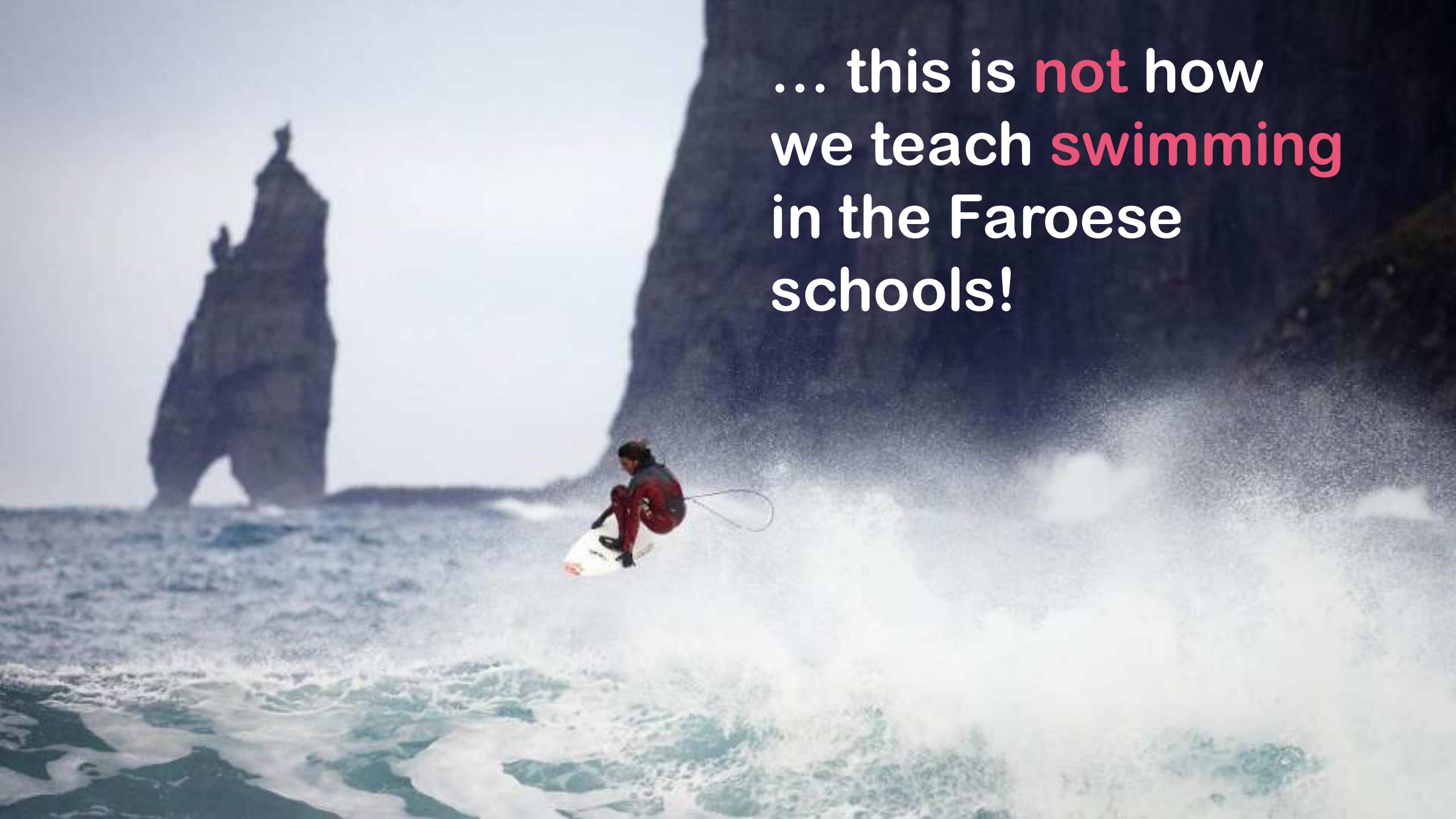

National curriculum

Swimming

The core area of swimming includes **the skills to swim**, to strengthen the student's ability to swim. This core area also includes information on **training** and **swimming-related hazards**, such as **basic lifesaving** techniques and **first aid**.

The pupil should be able to:

Grade 1-2

7-8 yr

- **water safety** and **self-saving**
- to take the **swimming** test in **Nósi**, where possible

Grade 3-4

7-8 yr

- to point out and explain about various **rescue methods** and **first aid**
- and knows different ways to **save themselves**.

Grade 5-6

11-12 yr

- or knows **rescue/self-rescue techniques**
- or knows **how to help** if and **accident occurs without endangering themselves**
- **breaststroke, crawl, backcrawl, self-rescue swimming, saving a tired swimmer**.

Grade 7-9

13-15 yr

- to **act and behave safely in water and afloat** (á floti!).

Grade 10

16 yr

- to further develop their skills from previous levels.

Why should we learn **to swim** in the Faroe Islands?

National curriculum

Swimming

The core area of swimming includes **the skills to swim**, to strengthen the student's ability to swim. This core area also includes information on **training** and **swimming-related hazards**, such as **basic lifesaving** techniques and **first aid**.

The pupil should master:

Grade 1-2
7-8 yr

- **water safety** and **self-saving**
- to take the **swimming** test in **Nósi**, where possible

Grade 3-4
7-8 yr

- to point out and explain about various **rescue methods** and **first aid**
- and knows different ways to **save themselves**.

Grade 5-6
11-12 yr

- or knows **rescue/self-rescue techniques**
- or knows **how to help** if an **accident** occurs **without endangering themselves**
- **breaststroke, crawl, backcrawl, self-rescue swimming, saving a tired swimmer**.

Grade 7-9
13-15 yr

- to **act and behave safely in water** and **afloat** (á floti!).

Grade 10
16 yr

- to further develop their skills from previous levels.



Why should we learn to swim in the Faroe Islands?

National curriculum

Swimming

The core area of swimming includes **the skills to swim**, to strengthen the student's ability to swim. This core area also includes information on **training** and **swimming-related hazards**, such as **basic lifesaving** techniques and **first aid**.

The pupil should master:

- **water safety** and **self-saving**
- to take the **swimming** test in **Nósi**, where possible
- to point out and explain about various **rescue methods** and **first aid**
- and knows different ways to **save themselves**.
- or knows **rescue/self-rescue techniques**
- or knows **how to help** if an **accident** occurs **without endangering themselves**
- **breaststroke, crawl, backcrawl, self-rescue swimming, saving a tired swimmer.**
- to **act and behave safely in water** and **afloat** (á floti!).
- to further develop their skills from previous levels.

Grade 1-2
7-8 yr

Grade 3-4
7-8 yr

Grade 5-6
11-12 yr

Grade 7-9
13-15 yr

Grade 10
16 yr



Why should we learn ~~to swim~~ in the Faroe Islands?

...aquatics?



Prevent
drowning?



... aquatically

Physically
literate?

Vatnvanur?

... at home in water?

**Inspire
passion?**



... aquatically

Physically literate?

Vatnvanur?

... at home in water?

Prevent drowning?

Does current
swim teaching
transfer the
curriculum?

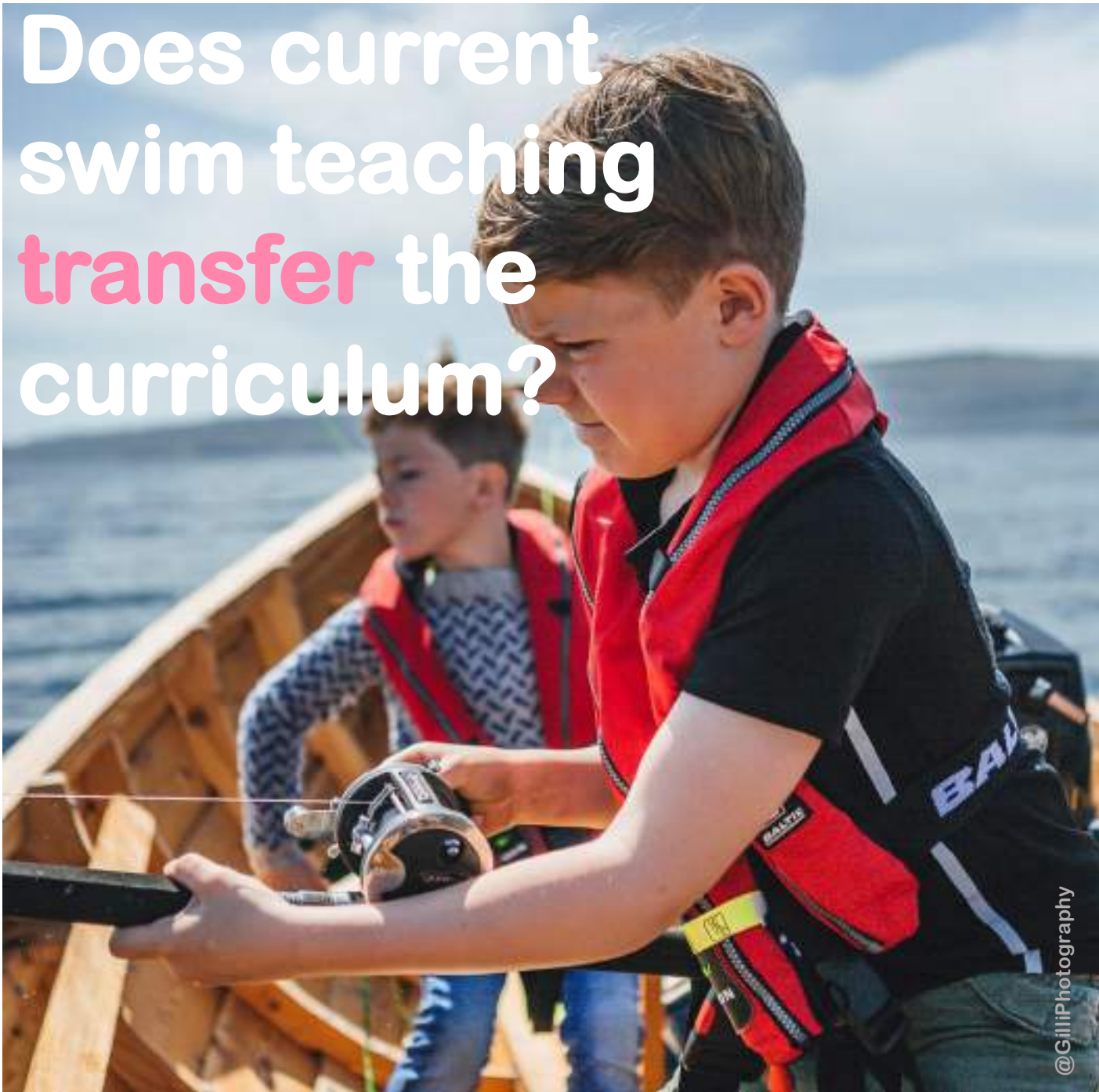

Schooling for Aquatic Literacy

How do we become vatnvon?

THE **PAL** EFFECT

A ~~Faroe Islander's~~ Quest for Swimming Glory

...Nation's...

ROD GILMOUR



Change the Paradigm— Develop Physical Literacy in Aquatic Environments



...the concept of swimming ability be replaced by the more encompassing notion of water competence with regards to drowning prevention. [sic]

—(Brenner, Moran, Stallman, Gilchrist, & McVan, 2006, p. 116)



Elizabeth Blank

Dudley 2019, Physical Literacy in Aquatic Environments

Where are we now?

“... highly prescriptive and controlled swimming programs are often **supported by government and reinforced by school curricula.**”

What would need to change?

“...A questioning of the command and **highly controlled learning model** that is predominantly being used.”

Where do we want to be?

1. Dynamic programs with **exposure** to multiple situations.
2. **Model-based** on a wide range of swimming **competencies.**
3. Models constructed on all **domains** of physical literacy.

What do we
observe from
school-swimming?

Student observations 12-year-olds

They always start swimming 20 lanes... and the final 5 lanes the pupils decide how they swim.

The teachers use 30 minutes for this activity and after that, everyone can play.

Somehow it seemed like this was normal for them – they did it because they knew they had to do it.

Student: Is it fun to swim?

Child: Yes.

Student : I won't tell anyone.

Chld: Okay, it sucks.

Student: What sucks?

Child: I cannot breathe and when I have swum for a while I get a headache. And there is no room to swim.

Why not play to learn?



Student: Is it fun to swim?

Child: I do not like to be last, because the others get to play.



Student observations 12-year-olds

Student: How can it be that you are not swimming today?

Child: Because I do not want to, I do not find it fun to swim.

Student: Do you usually swim?

Child: No.

Student: Do you think it is fun to swim?

Child: No, not like this.

...when we later asked the teachers how it was with this student, they said: “**Ooh, that student, this is one of the good students and he actually always swims.** The reason he's not swimming today is because he's been to the dentist”.

What somehow surprises me is that the **pupil and teacher do not say the same.**

How do we teach
PETE to promote an
understanding of
transfer with
students?

How do we
become
vatnvon?

How does a movement mean?

- * Meaning is like a number of other elusive concepts.
You know it, when you see it, but it is hard to describe it in its absence.

Fortunately, most of us have seen it. Meaningful movement has impacted our life for the better. Our personal stories have been shaped by it. **We identify ourselves as bikers, swimmers, table tennis players, hikers.**

We do not need to be told that delight can be found running across a grassy field or careening down snowy mountain slopes.

“The trick is to find ways to help others negotiate the same journey.”

R. Scott Kretchmar *

* Fletcher et al. 2021, Meaningful Physical Education



**Where does the
journey start?**







Vatnvon



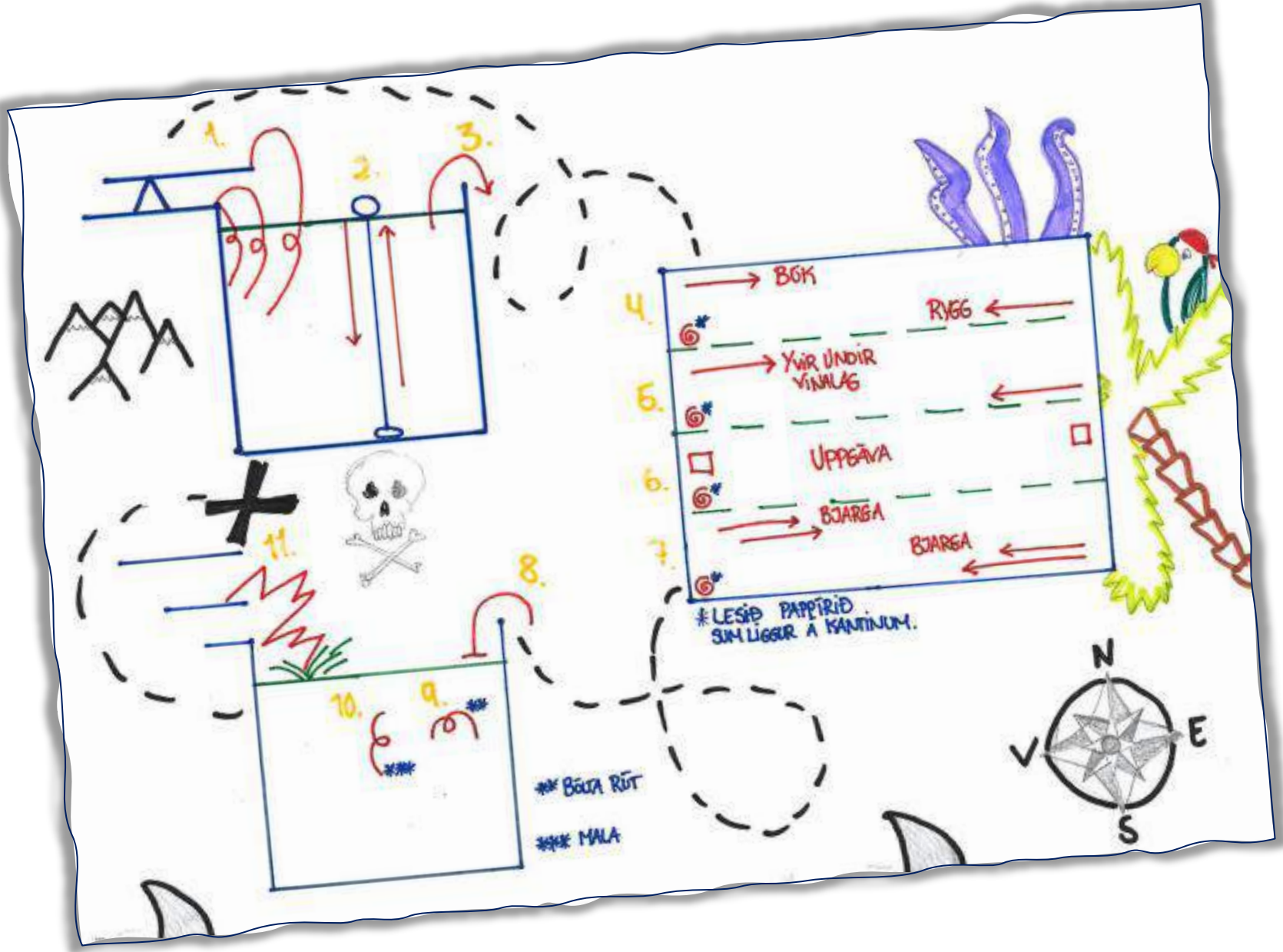

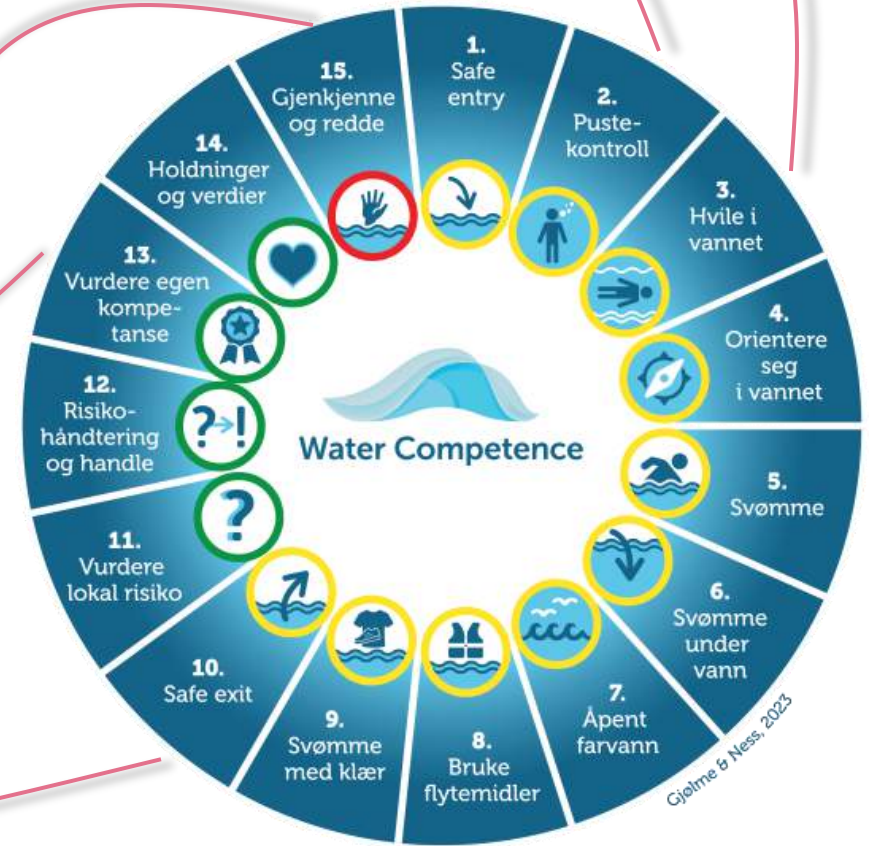
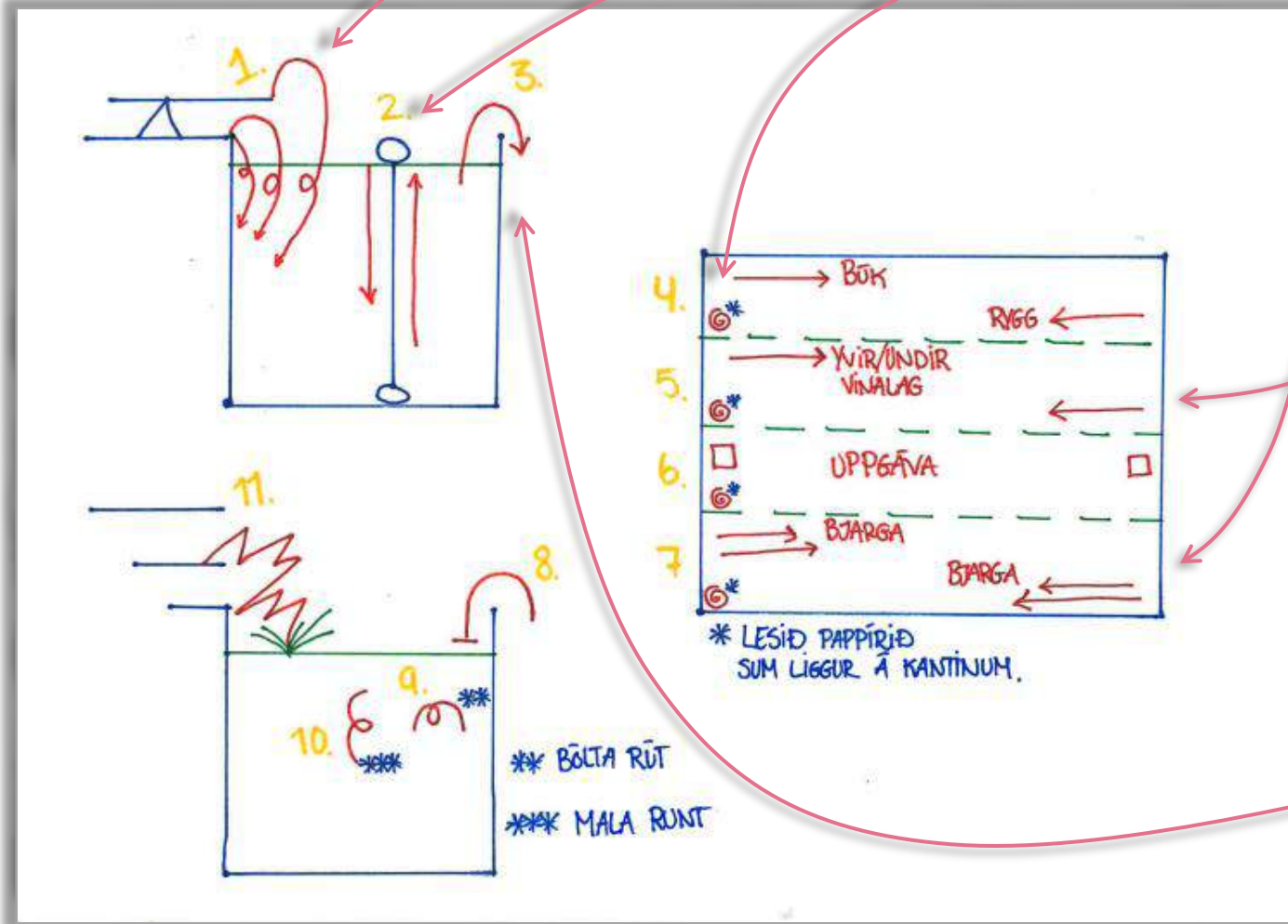

Then, how do we
picture a Faroese
society that has
become

VATNVANUR?



My grandmother has swum for as long as I can remember.

She possesses such a great genuineness and such **respect for the ocean.**

I've never encountered any other human able to **share such a bond** with anything – but another fellow human.

Because it's not really **that much about swimming.** It's about human and nature.

A **love story** about her and the ocean.

... we never look for the simplest solution. Which might exist just outside their front door like for example the ocean.

[Link to video](#)







Thank you